

TWIN TWIN BUNK BED ASSEMBLY:

STEP #1 (SEE #01 ILLUSTRATION)

INSERT DOWELS (PART F) INTO BOTH ENDS OF ALL SIDE RAILS.

STEP #2 (SEE #02 ILLUSTRATION)

INSERT DOWELS OF SIDE RAIL INTO TALL HEAD BOARD POSTS, USE BOLT (A) INTO NUT (C) AND TIGHTEN.

STEP #3 (SEE #03 ILLUSTRATION)

INSTALL ONE SLAT KIT ON THE BED JUST ASSEMBLED. USE SCREW (PART D) AND SCREW DOWN FIRST SLAT, LAST SLAT AND THEN THE MIDDLE SLAT. THE FIRST AND LAST SLAT MUST START AT THE BEGINNING OF THE SIDE RAIL CLEAT. MAXIMUM 3.25" AIR SPACE FROM SLAT TO END OF HEAD BOARDS.

STEP #4 (SEE #04 ILLUSTRATION)

INSERT DOWEL AT END OF THE SIDE RAIL INTO THE FOOT BOARD POST ATTACH WITH BOLT (A) INTO NUT (C). ATTACH GUARD RAILS WITH BOLT (A) INTO NUT (PART C) AND TIGHTEN. WHEN ONE SIDE IS COMPLETE INSERT ALL DOWELS FROM SIDE RAILS AND GUARD RAILS INTO THE OTHER FOOT BOARD SECTION WITH BOLT (A) INTO NUT (C) AND FULLY TIGHTEN.

STEP #5 (SEE #05 ILLUSTRATION)

INSTALL ONE SLAT KIT ON THE BED JUST ASSEMBLED. USE SCREW (PART D) AND SCREW DOWN FIRST SLAT, LAST SLAT AND THEN THE MIDDLE SLAT. THE FIRST AND LAST SLAT MUST START AT THE BEGINNING OF THE SIDE RAIL CLEAT. MAXIMUM 3.25" AIR SPACE FROM SLAT TO END OF FOOT BOARDS.

STEP #6 (SEE #06 ILLUSTRATION)

PUT THE BIG DOWELS (PART E) IN THE HOLES AT THE TOP OF THE HEAD BOARD POSTS. WITH TWO PEOPLE TAKE CARE AND LIFT THE FOOT BOARD SECTION AND INSERT INTO THE DOWELS ON TOP OF THE HEAD BOARDS. HEAVY LIFTING, TAKE CAUTION.

STEP #7 (SEE #07, 08 ILLUSTRATION)

ATTACH THE SMALL GUARD RAILA (08) INTO POST (06) WITH BOLT (G) AND TIGHTEN . IN THE OTHER END OF THE GUARD RAIL BOARDS INSERT DOWELS (PART F). NOW INSTALL THE GUARD RAIL INTO THE FOOT BOARDS BY INSERTING DOWELS INTO HOLES AND INSERT AND TIGHTEN BOLTS (H). USE SCREW (D) TO ATTCH GUARD RAIL TO POST. IN THE HOLES ON THE SIDE OF THE ENTRY USE BOLT (A) INTO NUT (I) AND TIGHTEN.

SIZE OF MATTRESS

THIS BED IS DESIGNED TO USE A MATTRESS (74" TO 75") LONG AND (37.5" TO 38.5") IN WIDTH AND THE ENCLOSED SLAT KIT SYSTEM. THE TOTAL THICKNESS OF UPPER OR LOWER MATTRESS AND FOUNDATION MUST NOT EXCEED 9.25". NOTE THERE MUST BE AT LEAST 5" FROM MATTRESS SLEEPING SURFACE TO TOP EDGE OF GUARDRAIL.

REPLACEMENT PARTS

REPLACEMENT PARTS, INCLUDING ADDITIONAL GUARD RAILS MAY BE OBTAINED FROM ANY OF OUR INNOVATIONS DEALERS.

SAFETY WARNINGS

1. FOLLOW THE INFORMATION ON THE WARNINGS APPEARING ON THE UPPER BUNK END STRUCTURE AND ON THE CARTON. DO NOT REMOVE WARNING LABEL FROM BED.
2. ALWAYS USE THE RECOMMENDED SIZE MATTRESS OR MATTRESS SUPPORT, OR BOTH, TO HELP PREVENT THE LIKELIHOOD OF ENTRAPMENT OR FALLS.
3. SURFACE OF MATTRESS MUST BE AT LEAST 5 INCHES BELLOW THE UPPER EDGE OF GUARDRAILS.
4. DO NOT ALLOW CHILDREN UNDER 6 YEARS OF AGE TO USE THE UPPER BUNK.
5. PERIODICALLY CHECK AND ENSURE THAT THE GUARD RAIL, LADDER, AND OTHER COMPONENTS ARE IN THEIR PROPER POSITION, FREE FROM DAMAGE, AND THAT ALL CONNECTORS ARE TIGHT.
6. DO NOT ALLOW HORSEPLAY ON OR UNDER THE BED AND PROHIBIT JUMPING ON THE BED.
7. ALWAYS USE THE LADDER FOR ENTERING OR LEAVING THE UPPER BUNK.
8. DO NOT USE SUBSTITUTE PARTS. CONTACT MANUFACTURER OR DEALER FOR REPLACEMENT PARTS.
9. USE OF A NIGHT LIGHT MAY PROVIDE ADDED SAFETY PRECAUTION FOR A CHILD USING THE UPPER BUNK.
10. ALWAYS USE GUARD RAILS ON BOTH LONG SIDES OF THE UPPER BUNK.
11. IF THE BUNK BED WILL BE PLACED NEXT TO A WALL, THE GUARD RAIL THAT RUNS THE FULL LENGTH OF THE BED SHOULD BE PLACED AGAINST THE WALL TO PREVENT ENTRAPMENT BETWEEN THE BED AND THE WALL.
12. PROHIBIT MORE THAN ONE PERSON ON THE UPPER BUNK.
13. THE USE OF WATER OR SLEEP FLOTATION MATTRESSES IS PROHIBITED.
14. KEEP THESE INSTRUCTIONS FOR FUTURE REFERENCE.







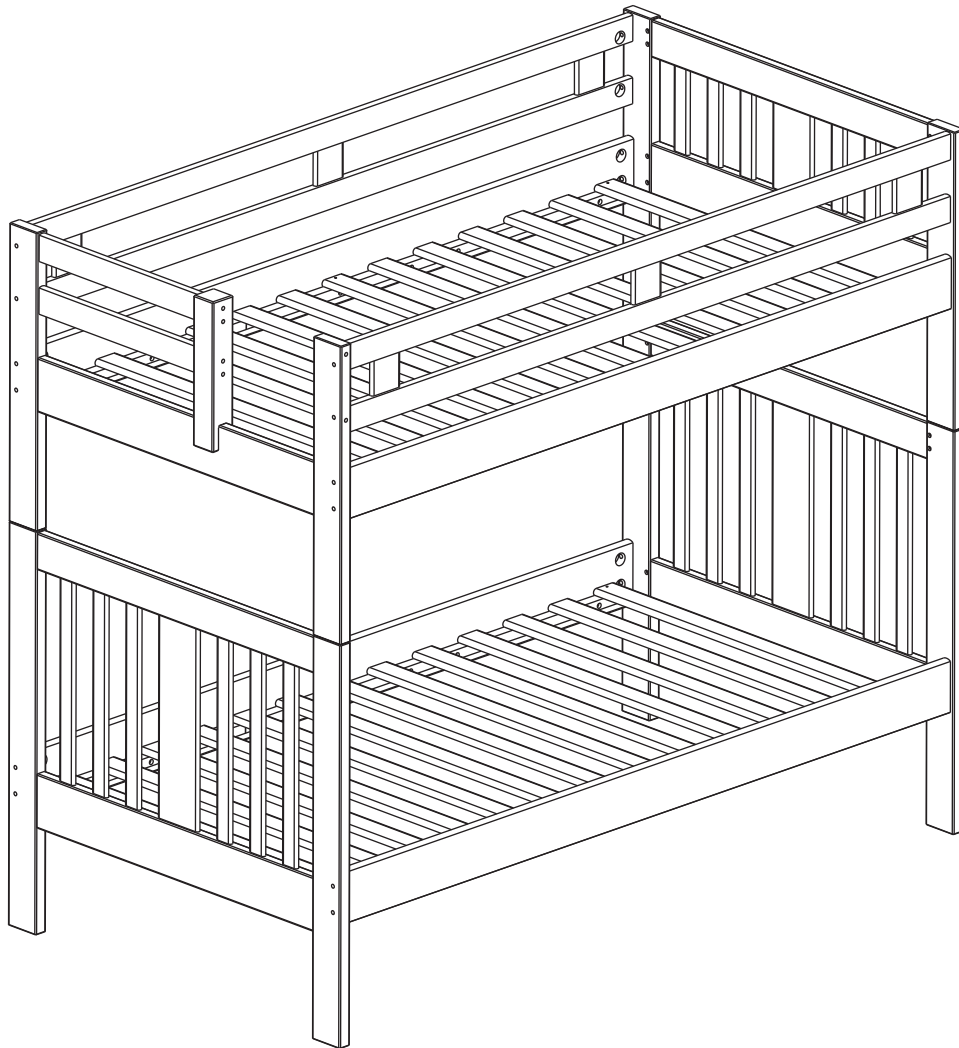

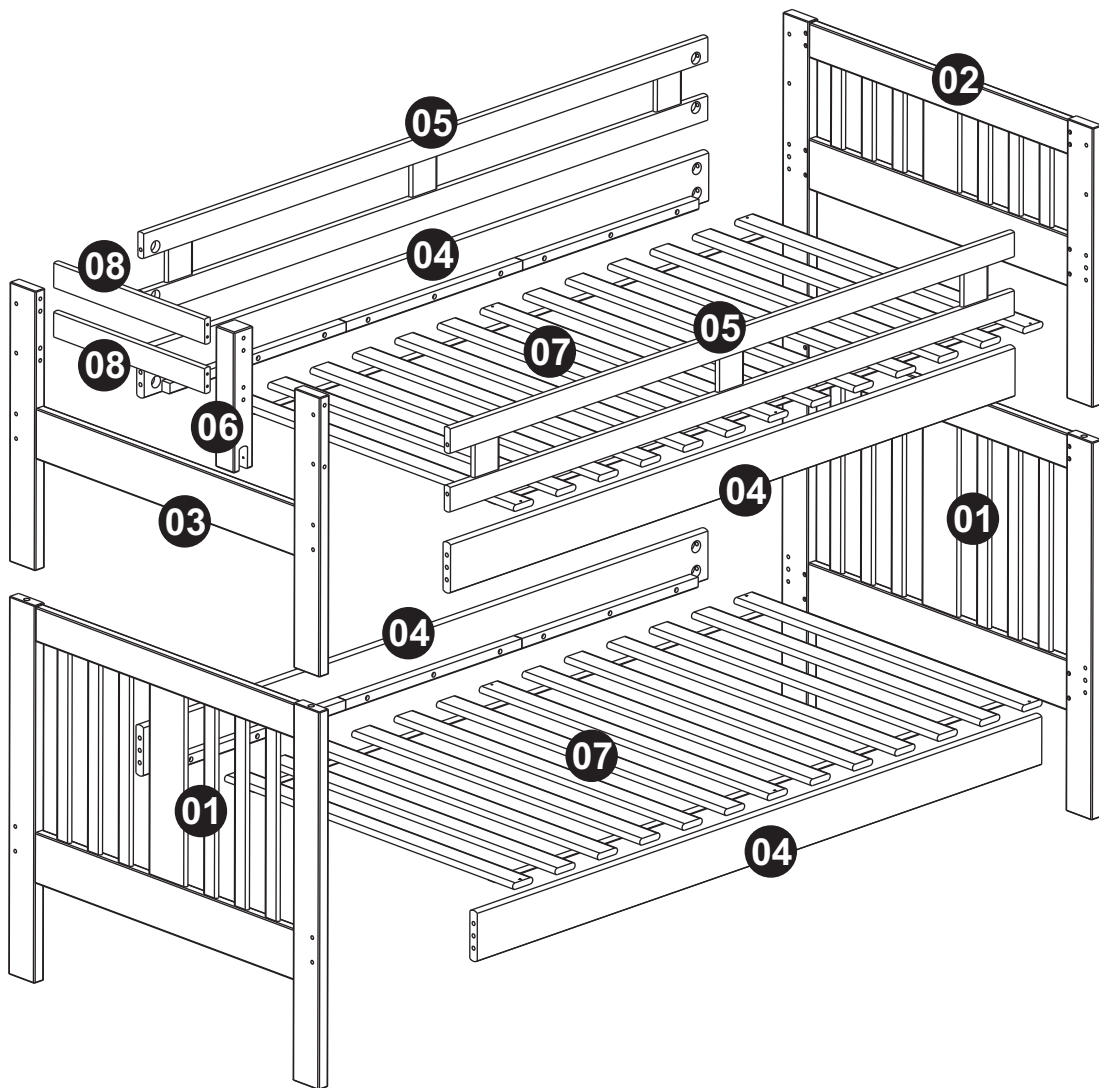
STRANGULATION HAZARD – NEVER ATTACH OR HANG ITEMS TO ANY PART OF THE BUNK BED THAT ARE NOT DESIGNED FOR USE WITH THE BED: FOR EXAMPLE, BUT NOT LIMITED TO HOOKS, BELTS AND JUMP ROPES.

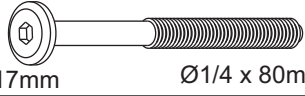
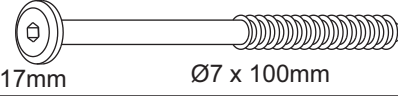
**DONCO TRADING
FORT WORTH, TX**

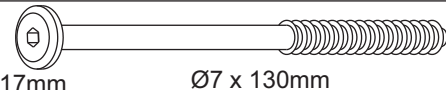
TWIN TWIN BUNK BED MODEL #215

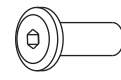

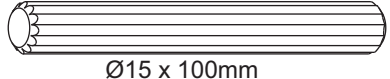

A	 17mm $\text{Ø}1/4 \times 80\text{mm}$	26	G	 17mm $\text{Ø}7 \times 100\text{mm}$	04
B		01	H	 17mm $\text{Ø}7 \times 130\text{mm}$	02
C	 1/4	24	I	 1/4	02
D	 $\text{Ø}3,5 \times 30\text{mm}$	14			
E	 $\text{Ø}15 \times 100\text{mm}$	04			
F	 $\text{Ø}10 \times 40\text{mm}$	10			

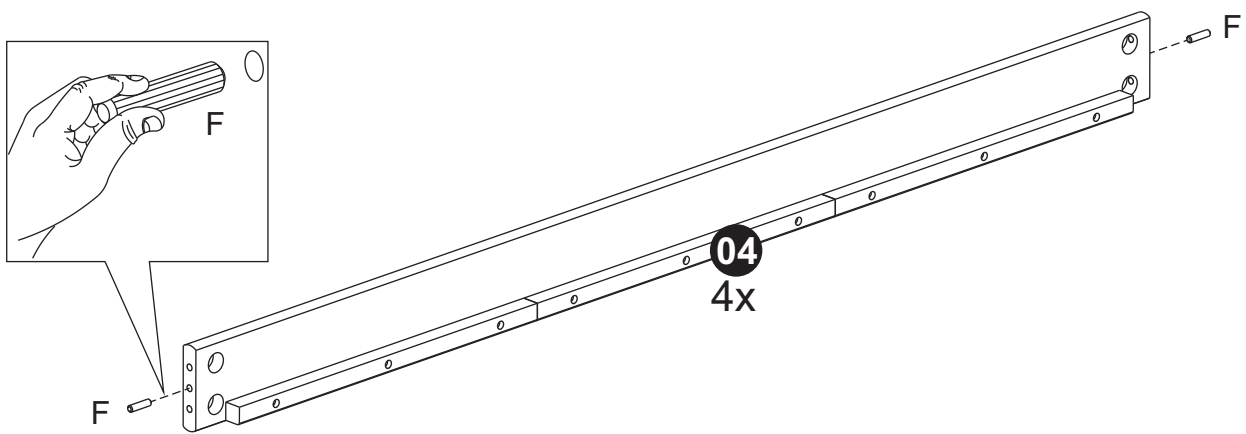

Step 01

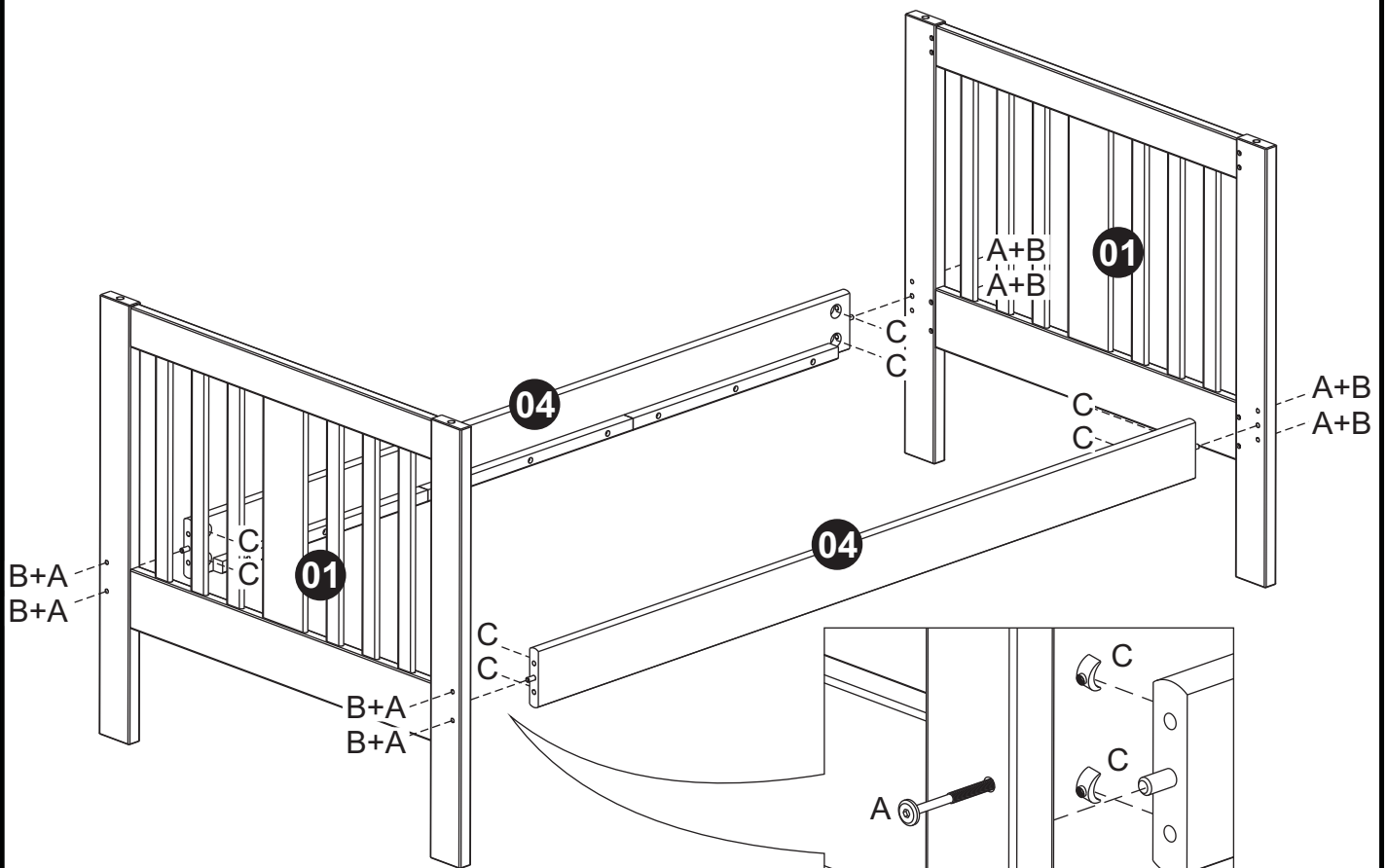

F	 Ø10 x 40mm	08
---	---	----

Step 02

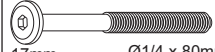

A	 17mm Ø1/4 x 80mm	08
B		01
C	 1/4	08

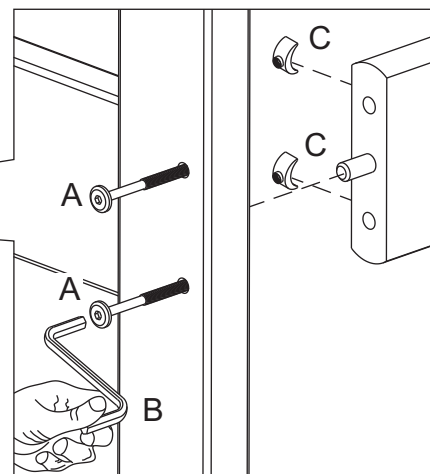



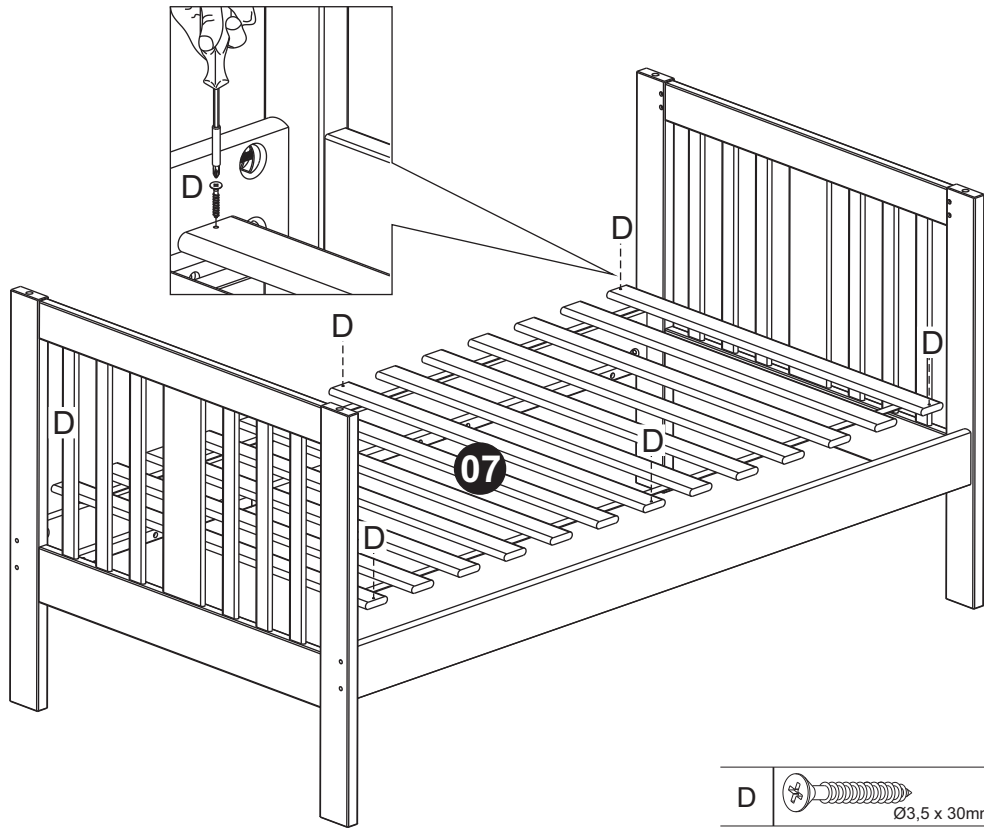

Step 03

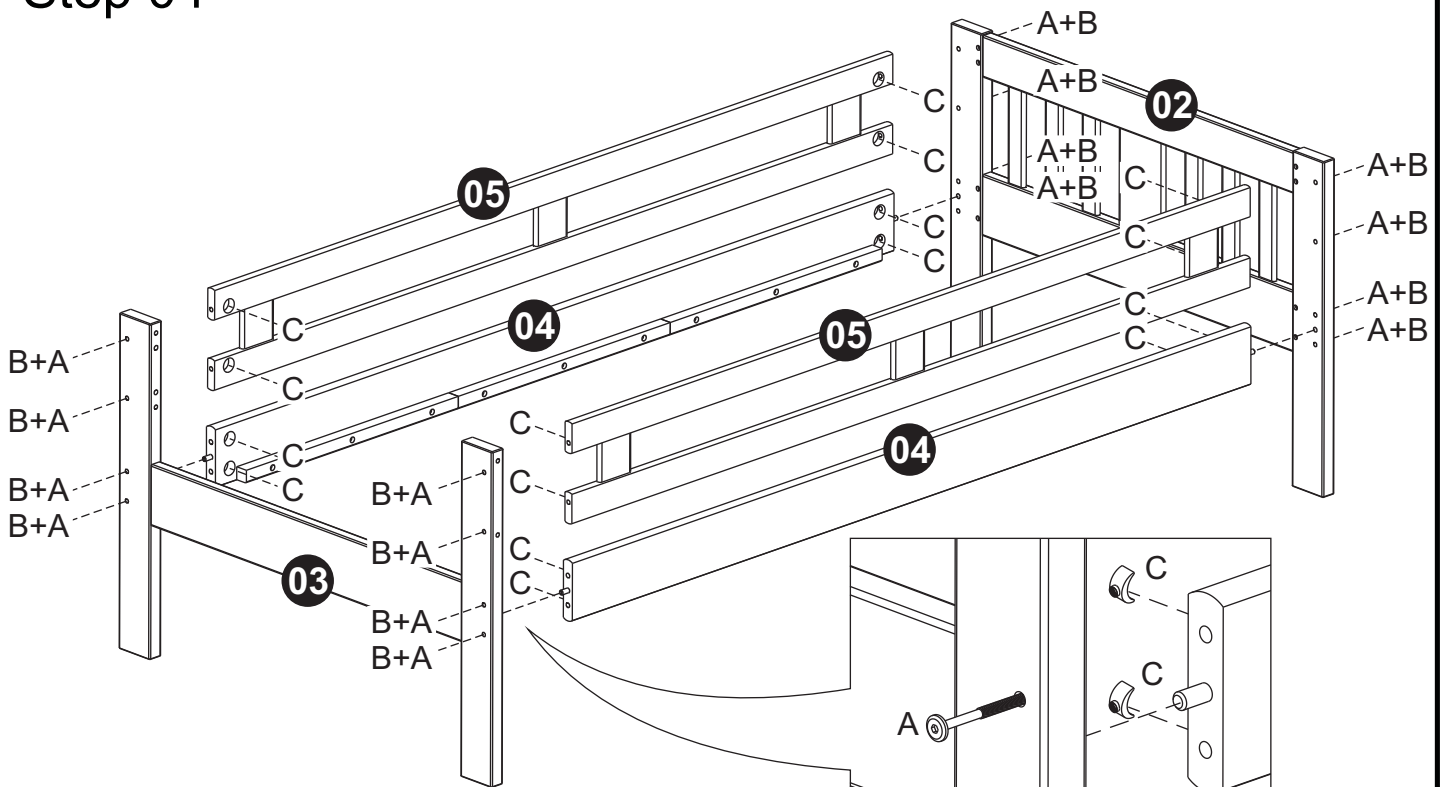

D		06
Ø3,5 x 30mm		

Step 04



A		16
17mm Ø1/4 x 80mm		
B		01
C		16
1/4		

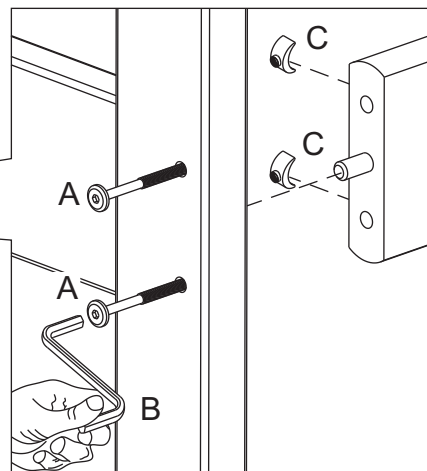

Step 05

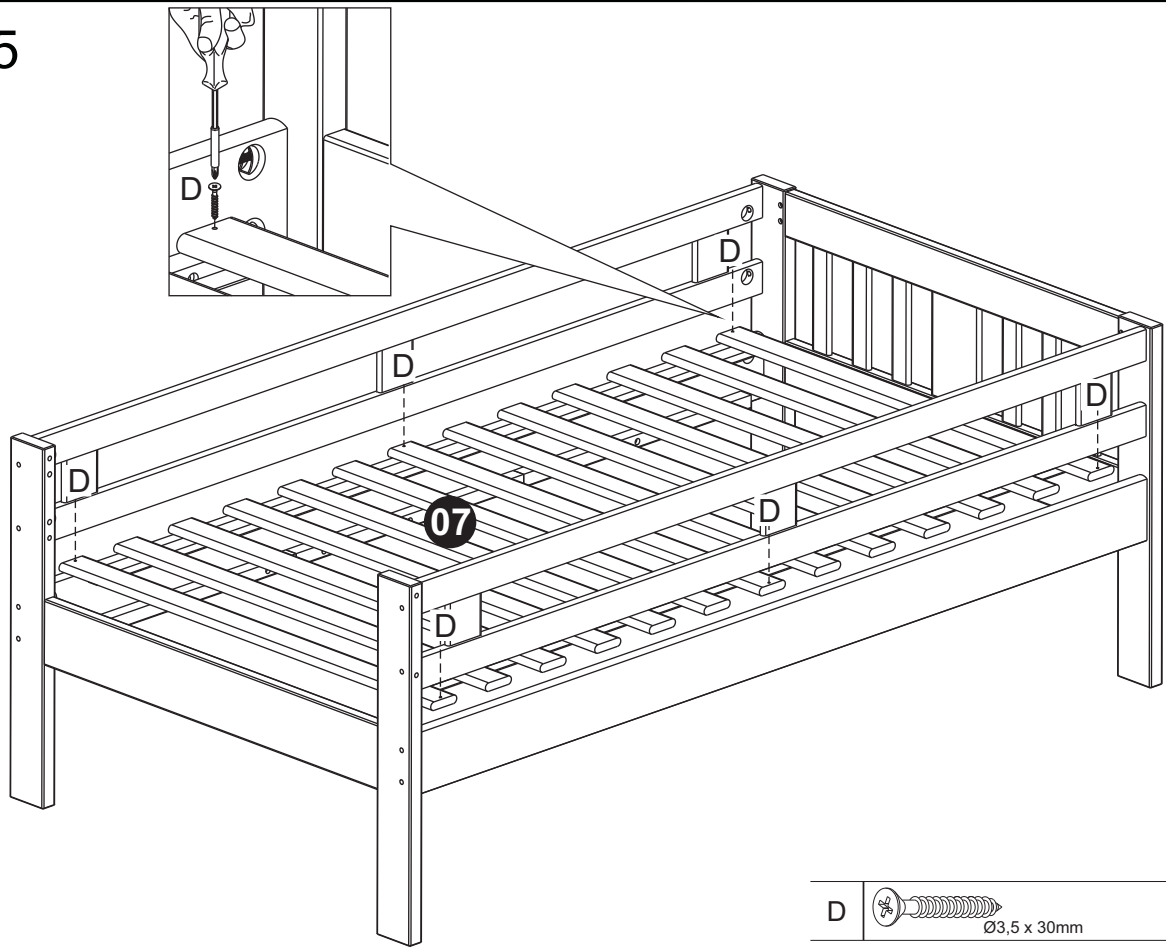

Step 06

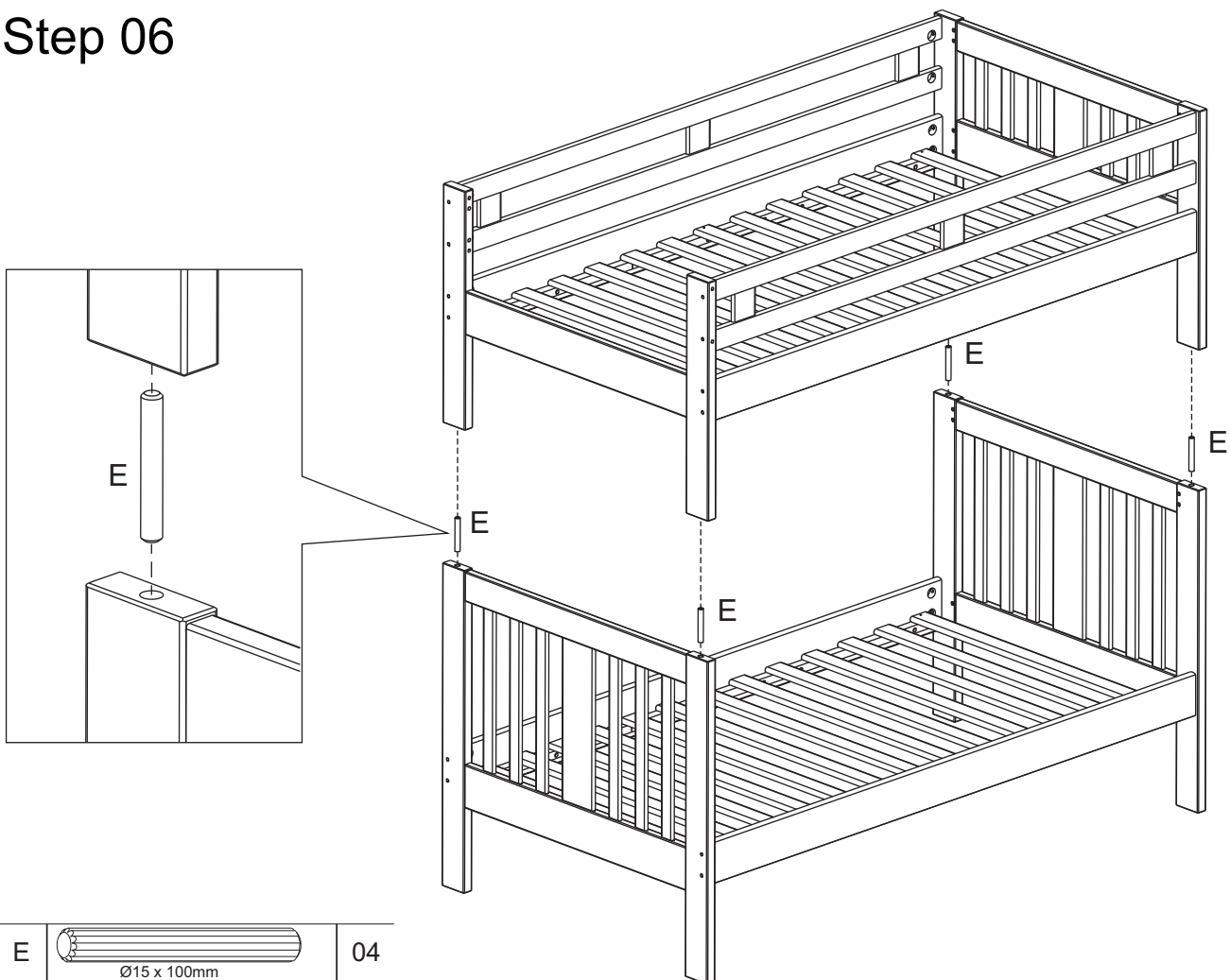

Step 07

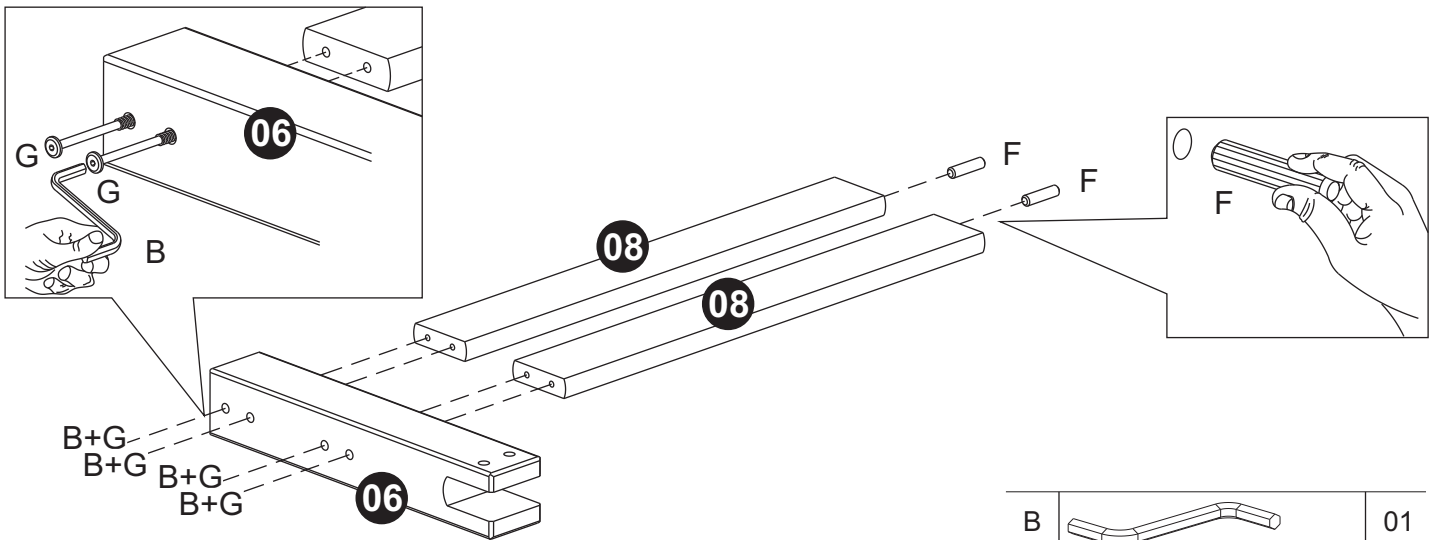

B		01
F	 Ø10 x 40mm	02
G	 17mm Ø7 x 100mm	04

Step 08

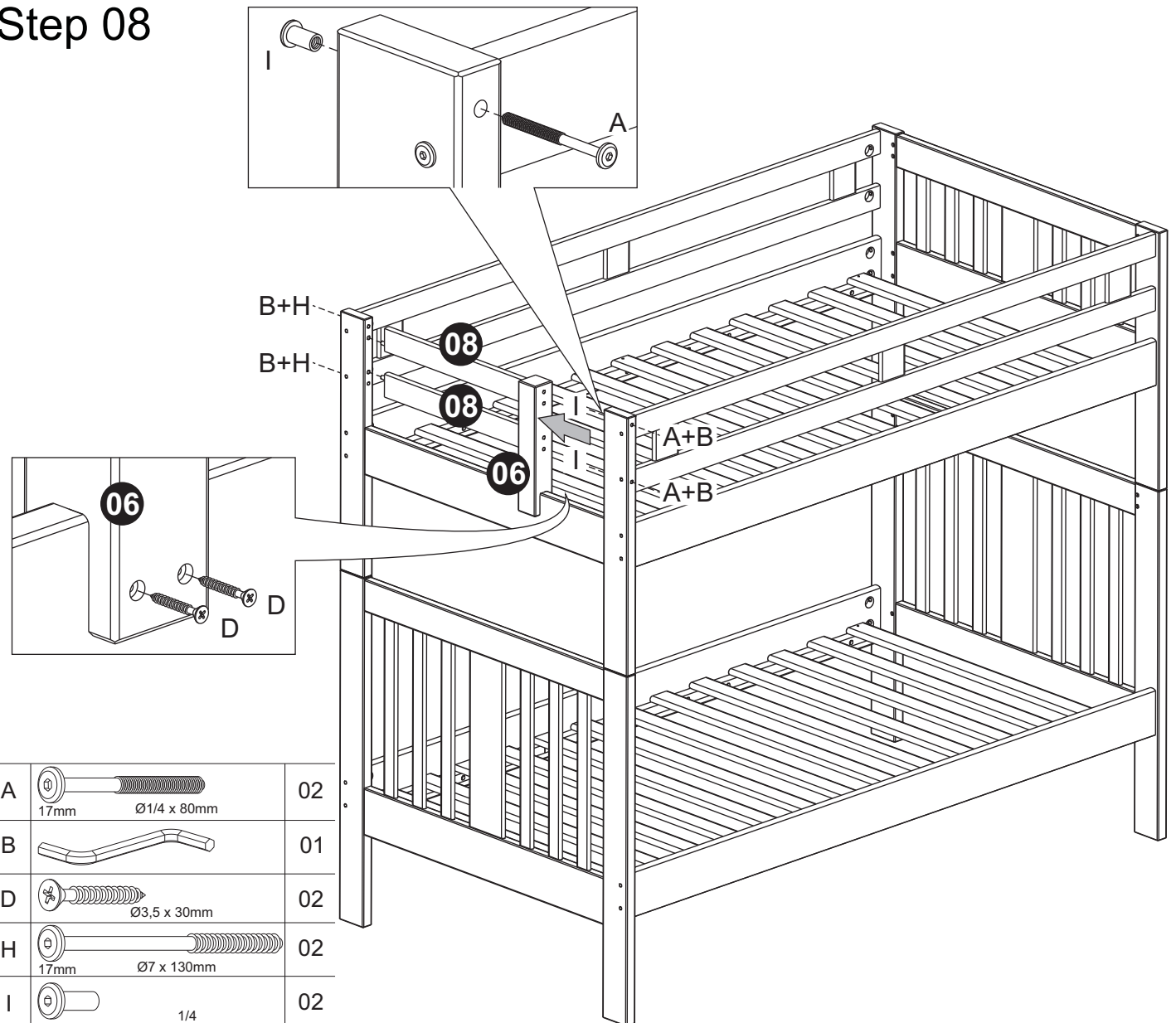

A	 17mm Ø1/4 x 80mm	02
B		01
D	 Ø3,5 x 30mm	02
H	 17mm Ø7 x 130mm	02
I	 1/4	02